

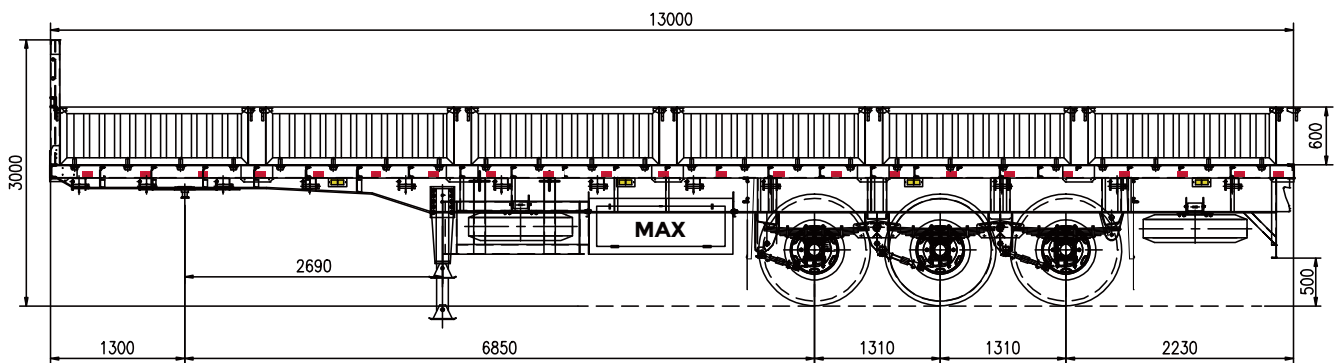

## Max 40 Foot Tri-axle Side Wall Trailer Quotation



**Note:** The photo and drawing are for reference only. The final design of the semi trailer is upon your specific requirements.



## Max 40 Foot Tri-axle Side Wall Trailer Quotation

<b>Model</b>	MAX/ST/SW/40/001
<b>Tare Weight</b>	7,800 KG, tolerance 0~-4%
<b>Payload</b>	60,000 KG
<b>G.V.W.</b>	67,800 KG
<b>Dimensions</b>	12500mm(Length) × 2500mm(Width) × 2500 - 3260 mm(Height, customizable)
<b>Side Wall</b>	600 mm high collapsible sidewalls, Side wall height is customizable
<b>Platform</b>	3 mm checkered steel plate
<b>King Pin</b>	MAX brand 2.0/3.5" bolt-in type
<b>Landing Gear</b>	MAX brand 2 speed, manual operating, heavy duty landing gear landing gears
<b>Main Beams</b>	Q345B high quality steel, Top flange 16 mm thick, bottom 16 mm, flange width both 140mm; web height 500 mm, 8 mm thick
<b>Axles</b>	MAX brand 13 ton axles, 3 units
<b>Suspensions</b>	MAX brand standard mechanical suspensions
<b>Springs</b>	10 lines of heavy duty leaf springs
<b>Brake System</b>	Dual air brake system, 6 air tanks,
<b>Rims</b>	9.00*22.5, 12 units
<b>Tires</b>	12R22.5, 12 units
<b>Electrical</b>	24-Volt sealed wiring harness, 7-pin connector at front
<b>Side Lights</b>	Two side marker lamps per side, amber color
<b>Rear Lights</b>	Standard brake, turn, reverse lights, license and fog lamp
<b>Toolbox</b>	One unit
<b>Spare wheels carriers</b>	One unit
<b>Reflectors</b>	Two triangular red reflectors at rear. Conspicuity reflective tapes on each side.
<b>Painting</b>	Sandblasting, one coat of primer, two coats of finish painting, and color as per customer's request.