



Lonely Lion

Semi Trailer Catalogue



CONTENTS

20 Foot Skeletal Semi Trailer	1
40 Foot Skeletal Semi Trailer	3
40 Foot Flatbed Semi Trailer.....	6
Side Wall Semi Trailer.....	8
Fence Semi Trailer	10
Grain Semi Trailer	13
Box Semi Trailer	15
Wood Log Semi Trailer	17
Tipper Semi Trailer	19
Side Tipper Semi Trailer.....	22
Container Side Loader	24
Fuel Tank Semi Trailer	26
Stainless Steel Tank Semi Trailer.....	29
Aluminum Tanker Trailer	32
Asphalt Bitumen Tanker Trailer	35
Sulfuric Acid Tanker Trailer	37
Dry Bulk Semi Trailer	39
Low Bed Semi Trailer	42
Extendable Semi Trailer.....	45
Removable Gooseneck Semi Trailer	46
Hydraulic Modular Trailer	48
Windmill Blade Adapter.....	49
Curtain Trailer	50
Full Drawbar Trailer.....	51
Car Carrier Semi Trailer	52

20 Foot Skeletal Semi Trailer

20 foot skeletal semi trailer is also called 20 foot skeleton semi trailer or 20 foot container chassis. They are widely used to transport 20 foot containers around the world.

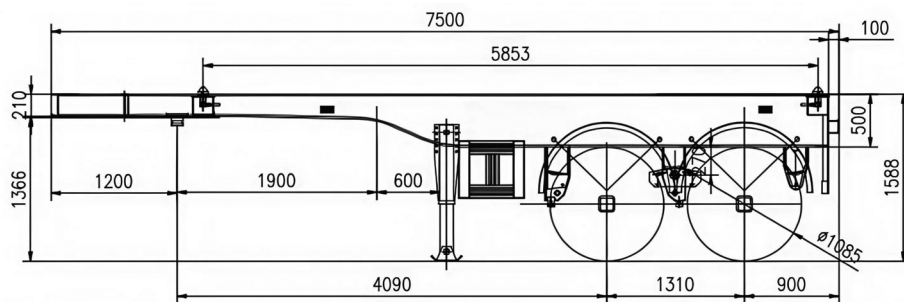
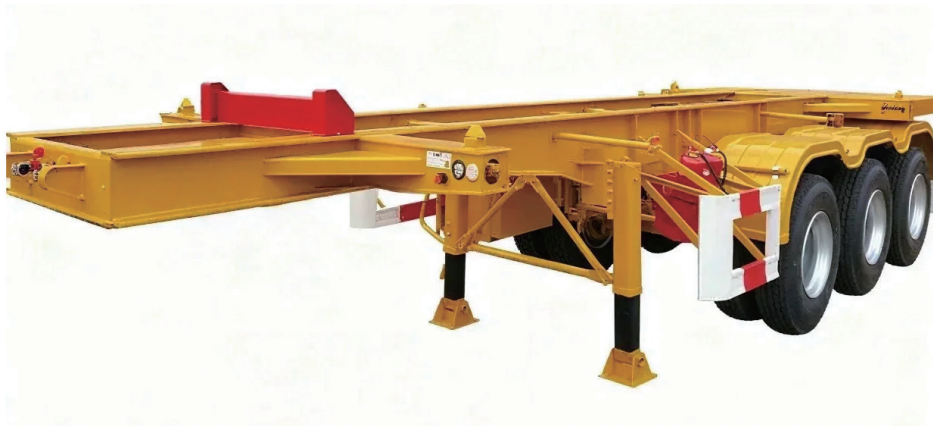
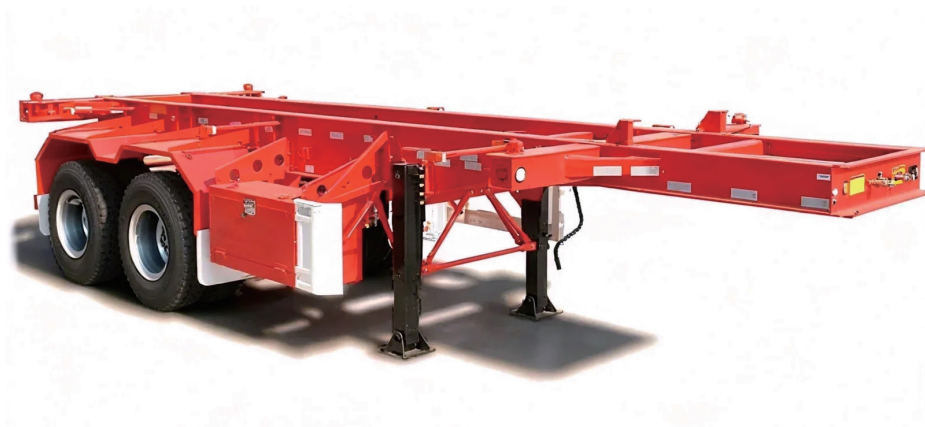

Specifications:

Dimensions(mm): 7500*2500*1588

Payload: 50 tons, depends on the number of axles and the loading capacity of the axles

Main Beams: Heavy duty and extra durability designed I beams. Made of high tensile Q345B steel, Top flange 14 mm thick, bottom 16 mm; web height 500 mm, 8 mm thick

Kingpin: 50#(2inch) or 90#(3.5inch) bolt-in type

Landing Gear: 28 ton landing gears with two mechanical speeds. Dynamic: 28 tons; Static 80 tons

Axles: 2 or 3 axles, 13 ton / 14 ton / 15 ton / 16 ton / 20 ton axles

Suspensions: mechanical suspensions or air suspensions

Springs: 10 lines of heavy duty leaf springs

Brake System: Dual air brake system

Rims: 9.00-22.5 or 9.75-22.5, 12 units

Tires: 12.00R22.5, 12 units

Electrical: 24 V Lighting system, 7 pole distribution cable and required hardware for traffic regulations

Twist Locks: Four ISO twist locks

Accessories: spare tire carrier + tool box

Painting: Sandblasting, one coat of primer, two coats of finish painting, and color as per customer's request.

40 Foot Skeletal Semi Trailer

A 40 foot skeletal semi trailer is also called a 40 foot skeleton semi trailer or a 40 foot container chassis semi trailer. One 40 foot skeletal semi trailer has 12 twist locks and can haul a 40 foot container, or two 20 foot containers. 40 foot skeleton semi trailers are widely used in global logistics industry.

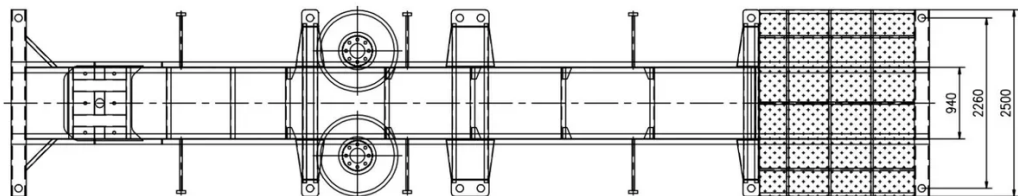
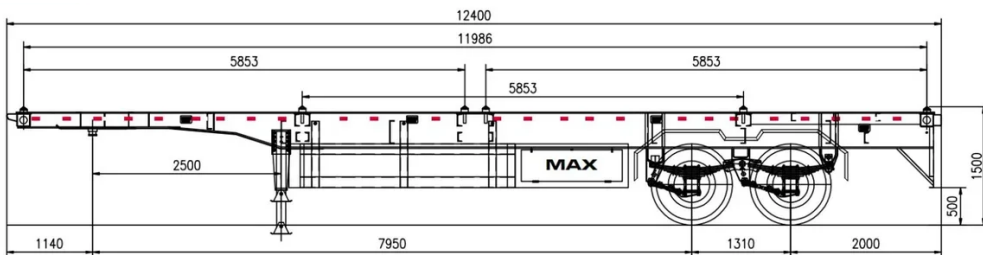

Two axle 40 foot skeletal semi trailer

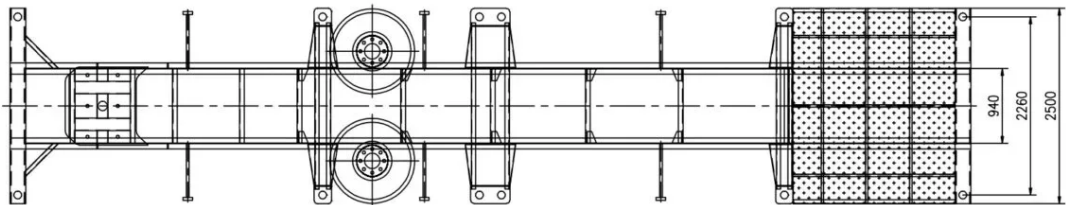
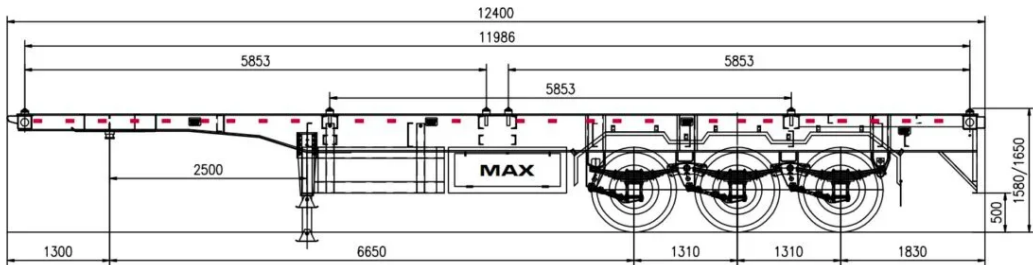

Three Axle 40 foot skeletal semi trailer

Specifications:

Dimensions(mm): 12500*2500*1550

Payload: 50 tons, depends on the number of axles and the loading capacity of the axles

Main Beams: Heavy duty and extra durability designed I beams. Made of high tensile Q345B steel, Top flange 14 mm thick, bottom 16 mm; web height 500 mm, 8 mm thick

Kingpin: 50#(2inch) or 90#(3.5inch) bolt-in type

Landing Gear: 28 ton landing gears with two mechanical speeds. Dynamic: 28 tons; Static 80 tons

Axles: 2 or 3 axles, 13 ton / 14 ton / 15 ton / 16 ton / 20 ton axles

Suspensions: mechanical suspensions or air suspensions

Springs: 10 lines of heavy duty leaf springs

Brake System: Dual air brake system

Rims: 9.00-22.5 or 9.75-22.5, 12 units

Tires: 12.00R22.5, 12 units

Electrical: 24 V Lighting system, 7 pole distribution cable and required hardware for traffic regulations

Twist Locks: Twelve ISO twist locks

Accessories: spare tire carrier + tool box

Painting: Sandblasting, one coat of primer, two coats of finish painting, and color as per customer's request.

40 Foot Flatbed Semi Trailer

A flatbed semi trailer is a 40 foot long, flat, open semi trailer. It has two functions. First, with 12 twist locks, It can be used to carry one 40 foot container or two 20 foot containers. Second, It can be used to haul general cargo. 40 foot flatbed semi trailers are among our most popular trailers for international markets.

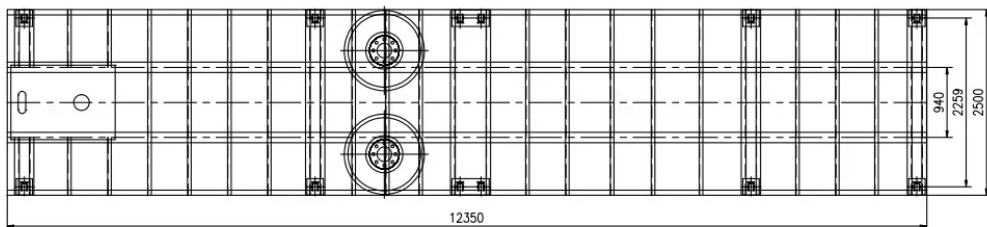
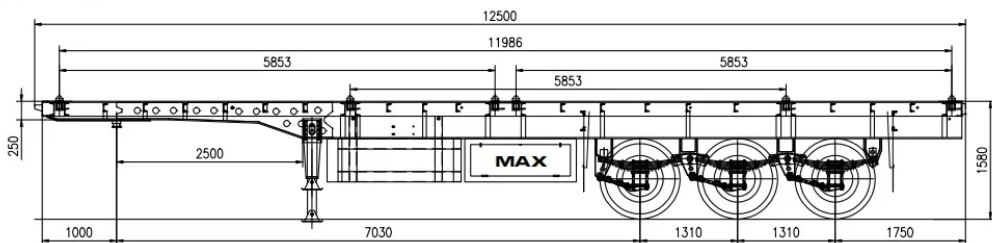

Specifications:

Dimensions(mm): 12500*2500*1550

Payload: 50 tons, depends on the number of axles and the loading capacity of the axles

Main Beams: Heavy duty and extra durability designed I beams. Made of high tensile Q345B steel, Top flange 14 mm thick, bottom 16 mm; web height 500 mm, 8 mm thick

Platform: 3mm thick checkered steel

Winches: optional

Kingpin: 50#(2inch) or 90#(3.5inch) bolt-in type

Landing Gear: 28 ton landing gears with two mechanical speeds. Dynamic: 28 tons; Static 80 tons

Axles: 2 to 4 axles, 13 ton / 14 ton / 15 ton / 16 ton / 20 ton axles, the regular configuration is three 13 ton axles and the payload will reach 50 tons

Suspensions: mechanical suspensions or air suspensions

Springs: 10 lines of heavy duty leaf springs

Brake System: Dual air brake system

Rims: 9.00-22.5 or 9.75-22.5, 12 units

Tires: 12.00R22.5, 12 units

Electrical: 24 V Lighting system, 7 pole distribution cable and required hardware for traffic regulations

Twist Locks: Twelve ISO twist locks

Accessories: spare tire carrier + tool box

Painting: Sandblasting, one coat of primer, two coats of finish painting, and color as per customer's request.



Side Wall Semi Trailer

Side wall semi trailers are also called drop side semi trailers. Side wall semi trailers are widely used to transport bulk cargo, vegetables & foods, steel, bagged cement and more.

Features of our side wall semi trailers

- The side walls are detachable and we can install twelve twist locks on the side wall semi trailer. So beside bulk cargo and general goods, you can also transport one 40 foot container or two 20 foot containers.
- The winches are welded on our side wall semi trailers so they will make it a lot more easier when you need to use the ropes to fasten the goods.





Specifications:

Dimensions(mm): 12500*2500

Side Wall Height(mm): 1000

Payload: 60 tons for three 13 ton axle configuration

Main Beams: Heavy duty and extra durability designed I beams. Made of high tensile Q345B steel, Top flange 14 mm thick, bottom 16 mm; web height 500 mm, 8 mm thick

Platform: 3mm thick checkered steel

Winches: optional

Kingpin: 50#(2inch) or 90#(3.5inch) bolt-in type

Landing Gear: 28 ton landing gears with two mechanical speeds. Dynamic: 28 tons; Static 80 tons

Axles: 2 to 4 axles, 13 ton / 14 ton / 15 ton / 16 ton / 20 ton axles, the regular configuration is three 13 ton axles.

Suspensions: mechanical suspensions or air suspensions

Springs: 10 lines of heavy duty leaf springs

Brake System: Dual air brake system

Rims: 9.00-22.5 or 9.75-22.5, 12 units

Tires: 12.00R22.5, 12 units

Electrical: 24 V Lighting system, 7 pole distribution cable and required hardware for traffic regulations

Twist Locks: Optional

Accessories: spare tire carrier + tool box

Painting: Sandblasting, one coat of primer, two coats of finish painting, and color as per customer's request.

Fence Semi Trailer

Fence semi trailers are also called stake semi trailers, livestock semi trailers. Fence semi trailers are widely used in the transportation industry. They are used to transport general cargo, vegetables & foods, daily necessities, and livestock. The usage of fence trailers are very wide.

Feature of our fence semi trailers

- The columns, sidewalls and columns can be detachable and we can install 12 twist locks on the fence trailer. So it can also be used to haul one 40 foot container or two 20 foot containers.
- The winches are welded on our fence semi trailers so you can fasten the goods or tarpaulin.

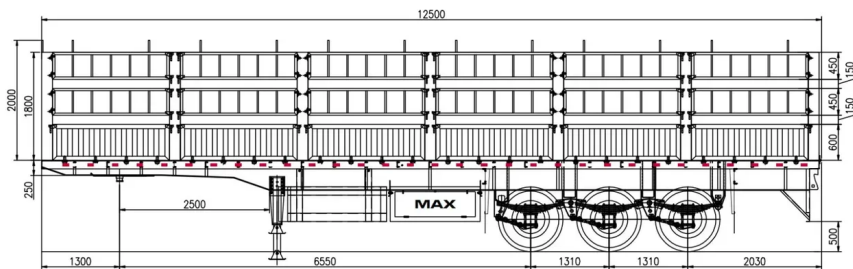
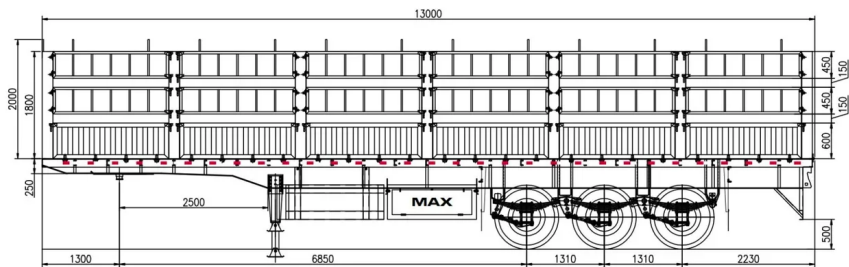

MX40FTFC01

MX13MFC01

Specifications:

Length: 12500 mm (40 foot) or 13000 mm, or as per customer's requirement

Width: 2500 mm

Height(mm): 3500 mm (sidewall + fence = 2000mm)

Sidewall: the height and style of the fences is customizable

Fence: the height and style of the fences is customizable

Payload: 60 tons for three 13 ton axle configuration

Main Beams: Heavy duty and extra durability designed I beams. Made of high tensile Q345B steel, Top flange 14 mm thick, bottom 16 mm; web height 500 mm, 8 mm thick

Platform: 3mm thick checkered steel

Winches: winches installed around the fence semi trailer

Kingpin: 50#(2inch) or 90#(3.5inch) bolt-in type

Landing Gear: 28 ton landing gears with two mechanical speeds. Dynamic: 28 tons; Static 80 tons

Axles: 2 to 4 axles, 13 ton / 14 ton / 15 ton / 16 ton / 20 ton axles, the regular configuration is three 13 ton axles.

Suspensions: mechanical suspensions or air suspensions

Springs: 10 lines of heavy duty leaf springs

Brake System: Dual air brake system

Rims: 9.00-22.5 or 9.75-22.5, 12 units

Tires: 12.00R22.5, 12 units

Electrical: 24 V Lighting system, 7 pole distribution cable and required hardware for traffic regulations

Twist Locks: Optional

Accessories: spare tire carrier + tool box

Painting: Sandblasting, one coat of primer, two coats of finish painting, and color as per customer's request.

Grain Semi Trailer

Grain semi trailer are side wall semi trailer which has a door at a side. The door makes the grain loading and unloading easier.

Features of Our Grain Semi Trailer

- It can be used to transport grain and other bulk commodity.
- The grain semi trailer can also be used to transport common goods and cargo
- It has twelve twist locks so it can haul one 40 foot container or two 20 foot containers.

We can also design and manufacture other types of gains semi trailers for you, just feel free to contact us!

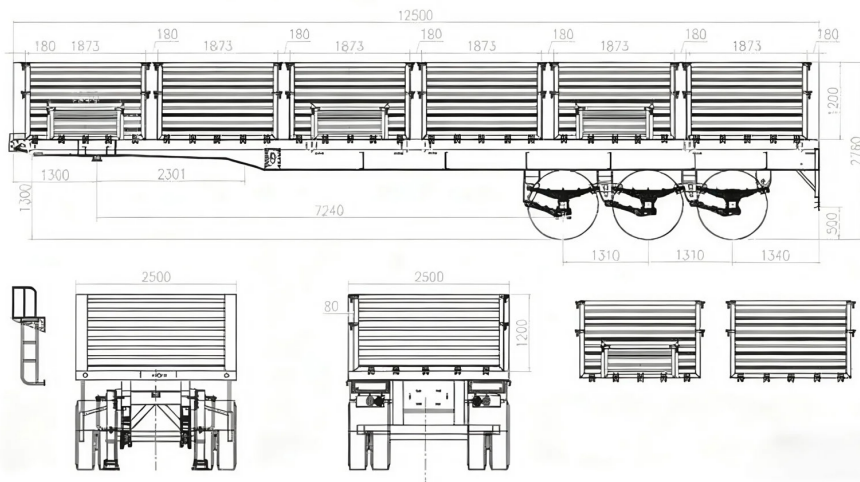

Specifications:

Dimensions(mm): 12500*2500*2780, length and height is customizable

Payload: 60 tons for three 13 ton axle configuration

Main Beams: Heavy duty and extra durability designed I beams. Made of high tensile Q345B steel, Top flange 14 mm thick, bottom 16 mm; web height 500 mm, 8 mm thick

Platform: 3mm thick checkered steel

Winches: installed

Kingpin: 50#(2inch) or 90#(3.5inch) bolt-in type

Landing Gear: 28 ton landing gears with two mechanical speeds. Dynamic: 28 tons; Static 80 tons

Axles: 2 to 4 axles, 13 ton / 14 ton / 15 ton / 16 ton / 20 ton axles, the regular configuration is three 13 ton axles

Suspensions: mechanical suspensions or air suspensions

Springs: 10 lines of heavy duty leaf springs

Brake System: Dual air brake system

Rims: 9.00-22.5 or 9.75-22.5, 12 units

Tires: 12.00R22.5, 12 units

Electrical: 24 V Lighting system, 7 pole distribution cable and required hardware for traffic regulations

Twist Locks: 12 ISO twist locks

Accessories: spare tire carrier + tool box

Painting: Sandblasting, one coat of primer, two coats of finish painting, and color as per customer's request.

Box Semi Trailer

A box semi trailer is also called a van semi trailer. They are widely used in world logistics industry to transport common goods and general cargo.



Specifications:

Dimensions(mm): 13000*2500*4000, length and height is customizable. Length can range from 7 meters to 18 meters or as per your requirements.

Doors: The number of doors on the sides and the back is as per your requirements. You can also customize the way the doors are opened.

Payload: 60 tons for three 13 ton axle configuration

Main Beams: Heavy duty and extra durability designed I beams. Made of high tensile Q345B steel, Top flange 14 mm thick, bottom 16 mm; web height 500 mm, 8 mm thick

Side Beams: 18mm steel channel (Material: Q235 steel)

Platform: 3mm thick checkered steel

Winches: installed

Kingpin: 50#(2inch) or 90#(3.5inch) bolt-in type

Landing Gear: 28 ton landing gears with two mechanical speeds. Dynamic: 28 tons; Static 80 tons

Axes: 2 to 5 axles, 13 ton / 14 ton / 15 ton / 16 ton / 20 ton axles, the regular configuration is three 13 ton axles

Suspensions: mechanical suspensions or air suspensions

Springs: 10 lines of heavy duty leaf springs

Brake System: Dual air brake system

Rims: 9.00-22.5 or 9.75-22.5, 12 units

Tires: 12.00R22.5, 12 units

Electrical: 24 V Lighting system, 7 pole distribution cable and required hardware for traffic regulations

Twist Locks: 12 ISO twist locks

Accessories: spare tire carrier + tool box

Painting: Sandblasting, one coat of primer, two coats of finish painting, and color as per customer's request.

Wood Log Semi Trailer

Wood log semi trailer is also called timber semi trailer. Our wood log semi trailer has three functions.

- The wood log semi trailer has bars around it so it can haul wood logs.
- It has a strong platform, so it can also haul general cargo.
- It has twelve twist locks so it can haul one 40 foot container or two 20 foot containers.

We can also design and manufacture other wood log semi trailers for you, just feel free to contact us!



Specifications:

Dimensions(mm): 12500*2500*3280

Payload: 60 tons for three 13 ton axle configuration

Main Beams: Heavy duty and extra durability designed I beams. Made of high tensile Q345B steel, Top flange 14 mm thick, bottom 16 mm; web height 500 mm, 8 mm thick

Platform: 3mm thick checkered steel

Winches: installed

Kingpin: 50#(2inch) or 90#(3.5inch) bolt-in type

Landing Gear: 28 ton landing gears with two mechanical speeds. Dynamic: 28 tons; Static 80 tons

Axles: 2 to 4 axles, 13 ton / 14 ton / 15 ton / 16 ton / 20 ton axles, the regular configuration is three 13 ton axles

Suspensions: mechanical suspensions or air suspensions

Springs: 10 lines of heavy duty leaf springs

Brake System: Dual air brake system

Rims: 9.00-22.5 or 9.75-22.5, 12 units

Tires: 12.00R22.5, 12 units

Electrical: 24 V Lighting system, 7 pole distribution cable and required hardware for traffic regulations

Twist Locks: 12 ISO twist locks

Accessories: spare tire carrier + tool box

Painting: Sandblasting, one coat of primer, two coats of finish painting, and color as per customer's request.

Tipper Semi Trailer

A tipper semi trailer is also called a end dump semi trailer. Tipper semi trailers are primarily used for transporting bulk and loose goods such as coal, ore, sand, gravel, soil grain.

Tipper Trailer Customization Options

- You can use 2 to 6 axles per trailer and the payload ranges from 40 tons to 100 tons or more.
- You can choose 13 ton / 14 ton / 15 ton / 16 ton / 20 ton axles
- The shape of the semi trailer is customizable. You can choose the regular box type, U type or other types you need.



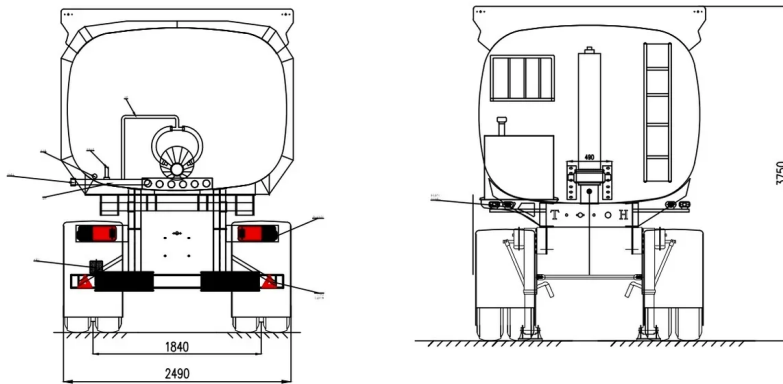
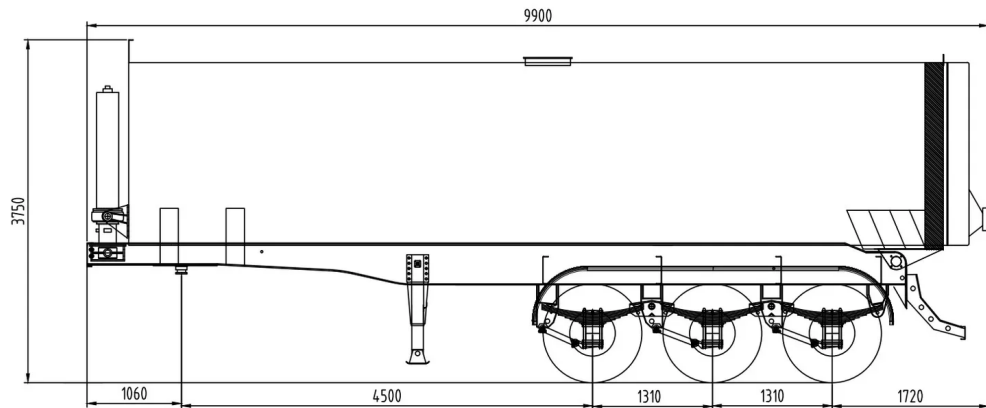

Note: This drawing is for reference only. We can design customized tipper trailers for you.

Specifications:

Dimensions(mm): 9300mmx2500mm x3482mm (inside dimension)

Lifting System: Full set of HYVA lifting cylinder

Payload: 60 tons for three 13 ton axle configuration

Main Beams: Heavy duty and extra durability designed I beams. Made of high tensile Q345B steel, Top flange 14 mm thick, bottom 16 mm; web height 500 mm, 8 mm thick

Kingpin: 50#(2inch) or 90#(3.5inch) bolt-in type

Landing Gear: 28 ton landing gears with two mechanical speeds. Dynamic: 28 tons; Static 80 tons

Axles: 2 to 5 axles, 13 ton / 14 ton / 15 ton / 16 ton / 20 ton axles, the regular configuration is three 13 ton axles

Suspensions: mechanical suspensions or air suspensions

Springs: 10 lines of heavy duty leaf springs

Brake System: Dual air brake system

Rims: 9.00-22.5 or 9.75-22.5, 12 units

Tires: 12.00R22.5, 12 units

Electrical: 24 V Lighting system, 7 pole distribution cable and required hardware for traffic regulations

Twist Locks: 12 ISO twist locks

Accessories: spare tire carrier + tool tipper

Painting: Sandblasting, one coat of primer, two coats of finish painting, and color as per customer's request.



Side Tipper Semi Trailer

Side tipper trailer is different from tipper trailer. A side tipper trailer dumps from a side while a tipper trailer dumps from the rear. Side tipper semi trailers are primarily used for transporting bulk and loose goods such as coal, ore, sand, gravel, soil grain.

Side tipper Trailer Customization Options

- You can use 3 to 6 axles per trailer and the payload ranges from 40 tons to 100 tons or more.
- You can choose 13 ton / 14 ton / 15 ton / 16 ton / 20 ton axles
- You can choose the shape and style of the trailer body



Specifications:

Volume: 35 cubic meters

Dimensions(mm): 8112mm x 2500mm x 3482mm (inside dimension), this dimensions are of a 35 cubic meter side dump trailer. The dimensions are based on the designed volume.

Lifting System: Lifting cylinder 5×130 bore, a shift cylinder

Payload: 60 tons for three 13 ton axle configuration

Main Beams: Heavy duty and extra durability designed I beams. Made of high tensile Q345B steel, Top flange 14 mm thick, bottom 16 mm; web height 500 mm, 8 mm thick

Kingpin: 50#(2inch) or 90#(3.5inch) bolt-in type

Landing Gear: 28 ton landing gears with two mechanical speeds. Dynamic: 28 tons; Static 80 tons

Axles: 2 to 6 axles, 13 ton / 14 ton / 15 ton / 16 ton / 20 ton axles, common configuration is three 13 ton axles

Suspensions: mechanical suspensions or air suspensions

Springs: 10 lines of heavy duty leaf springs

Brake System: Dual air brake system

Rims: 9.00-22.5 or 9.75-22.5, 12 units

Tires: 12.00R22.5, 12 units

Electrical: 24 V Lighting system, 7 pole distribution cable and required hardware for traffic regulations

Accessories: spare tire carrier + tool side tipper

Painting: Sandblasting, one coat of primer, two coats of finish painting, and color as per customer's request.

Container Side Loader

Side loader semi trailer offers a convenient solution for loading, transporting, and unloading containers.



Specifications:

Max Lifting Capacity: 45 tons

Dimensions(mm): 14100*2500*4200

Power Source: Power take-off (equipped)

Main Beams: Heavy duty and extra durability designed I beams. Made of high tensile Q345B steel, Top flange 14 mm thick, bottom 16 mm; web height 500 mm, 8 mm thick

Kingpin: 50#(2inch) or 90#(3.5inch) bolt-in type

Landing Gear: 28 ton landing gears with two mechanical speeds. Dynamic: 28 tons; Static 80 tons

Axles: three 13 ton axles

Suspensions: mechanical suspensions or air suspensions

Springs: 10 lines of heavy duty leaf springs

Brake System: Dual air brake system

Rims: 9.00-22.5 or 9.75-22.5, 12 units

Tires: 12.00R22.5, 12 units

Electrical: 24 V Lighting system, 7 pole distribution cable and required hardware for traffic regulations

Twist Locks: 12 ISO twist locks

Accessories: spare tire carrier + tool side tipper

Painting: Sandblasting, one coat of primer, two coats of finish painting, and color as per customer's request.

Fuel Tank Semi Trailer

Fuel tank semi trailers are widely used to transport fuel, petrol and oil. Since 2001, Max fuel tank semi trailer have been exported to Southeast Asia, South Asia, Middle Asia, the Middle East, Africa and more.

Fuel Tank Trailer Customization Options

- Capacity: 30,000 to 60,000 Liters
- Axles: 3 or 5
- Compartments: 1 to 7

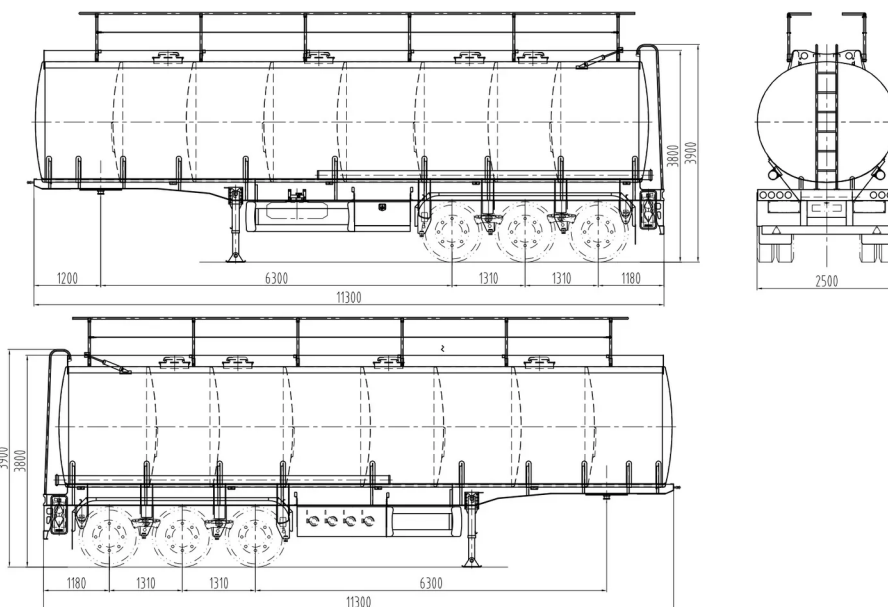

Specifications:

General Information

Capacity: 30,000 to 60,000 liters, as per your requirement

Dimensions(mm): 11500*2500*3700 (these dimensions are of a 45,000 liter tank trailer. The dimensions of a tank trailer depends on the capacity and design of it.)

King Pin: 50#(2inch) or 90#(3.5inch) bolt-in type

Tank Body

Tank Shape: Round or square

Tank Material: Q235B carbon steel, Tank shell thickness 5 mm, front and rear ends thickness 6mm. Thickness depends on capacity.

Compartments: 1 to 7 compartments, based on customer needs

Baffles: 5 mm thick baffles designed to permit the easy flow of fuel inside the tank

Manholes: Each compartment is equipped with 500mm carbon steel or aluminium alloy manhole cover fitted with bolts and nuts, internal safety valve built into the main hole.

Discharge: The tank is top loading through manholes and discharged by gravity through manually operated ball valves 3" or 4", located into a lockable discharged box (at one side of tank). Each compartment is equipped with a lower valves 3" or 4" .

Discharge Pipes: 4" rubber hose, 2 units, 6 metre/each

Walkway: The tank is equipped with upper walkway manufactured from stretched steel sheet and equipped with steel walkwall

Ladder: The tank is equipped with a front or rear ladder to facilitate the arrival to manholes.

Chassis

Landing Legs: 28 ton landing gears with two mechanical speeds. Dynamic: 28 tons; Static 80 tons

Main Beams: Heavy duty and extra durability designed I beam. Made of high tensile steel Q345B, welded by automatic Submerged-Arc processes. Top flange 14 mm thick, bottom 16 mm; web height 500 mm, 8 mm thick

Axes: MAX brand 13 ton axles, 3 – 4 units

Suspensions: Standard mechanical suspensions or air suspensions

Springs: 10 lines of heavy duty leaf springs

Brake System: Dual air brake system

Rims: 9.0-22.5

Tires: 12.00R22.5 tires, 12 units

Electrical: 24 V Lighting system, 7 pole distribution cable and required hardware for traffic regulations

Toolbox: One standard

Spare wheels carriers: Two pieces

Painting: Sandblasting, one coat of primer, two coats of finish painting, and color as per customer's request.

Stainless Steel Tank Semi Trailer

Stainless steel tank semi trailers are widely used to transport edible oil. Since 2001, Max stainless steel tank semi trailer have been exported to Southeast Asia, South Asia, Middle Asia, the Middle East, Africa and more.

Stainless Steel Tank Trailer Customization Options

- Capacity: 30,000 to 60,000 Liters
- Axles: 3 or 5
- Compartments: 1 to 7



Specifications:

General Information

Capacity: 30,000 to 60,000 liters, as per your requirement

Dimensions(mm): 11500*2500*3700 (these dimensions are of a 45,000 liter tank trailer. The dimensions of a tank trailer depends on the capacity and design of it.)

King Pin: 50#(2inch) or 90#(3.5inch) bolt-in type

Tank Body

Tank Shape: Round or square

Tank Material: Q235B stainless steel, Tank shell thickness 5 mm, front and rear ends thickness 6mm. Thickness depends on capacity.

Compartments: 1 to 7 compartments, based on customer needs

Baffles: 5 mm thick baffles designed to permit the easy flow of stainless steel inside the tank

Manholes: Each compartment is equipped with 500mm carbon steel or aluminium alloy manhole cover fitted with bolts and nuts, internal safety valve built into the main hole.

Discharge: The tank is top loading through manholes and discharged by gravity through manually operated ball valves 3" or 4", located into a lockable discharged box (at one side of tank). Each compartment is equipped with a lower valves 3" or 4" .

Discharge Pipes: 4" rubber hose, 2 units, 6 metre/each

Walkway: The tank is equipped with upper walkway manufactured from stretched steel sheet and equipped with steel walkwall

Ladder: The tank is equipped with a front or rear ladder to facilitate the arrival to manholes.

Chassis

Landing Legs: 28 ton landing gears with two mechanical speeds. Dynamic: 28 tons; Static 80 tons

Main Beams: Heavy duty and extra durability designed I beam. Made of high tensile steel Q345B, welded by automatic Submerged-Arc processes. Top flange 14 mm thick, bottom 16 mm; web height 500 mm, 8 mm thick

Axles: MAX brand 13 ton axles, 3 – 4 units

Suspensions: Standard mechanical suspensions or air suspensions

Springs: 10 lines of heavy duty leaf springs

Brake System: Dual air brake system

Rims: 9.0-22.5

Tires: 12.00R22.5 tires, 12 units

Electrical: 24 V Lighting system, 7 pole distribution cable and required hardware for traffic regulations

Toolbox: One standard

Spare wheels carriers: Two pieces

Painting: Sandblasting, one coat of primer, two coats of finish painting, and color as per customer's request.

Aluminum Tanker Trailer

Aluminum tank semi trailers are lighter than carbon steel tanker trailers and stainless steel tanker trailers so they consumes less fuel.

Since 2001, Max Aluminum tank semi trailer have been exported to Southeast Asia, South Asia, Middle Asia, the Middle East, Africa and more.

Aluminum Tank Trailer Customization Options

- Capacity: 30,000 to 60,000 Liters
- Axles: 3 or 5
- Compartments: 1 to 7



Specifications:

General Information

Capacity: 30,000 to 60,000 liters, as per your requirement

Dimensions(mm): 11500*2500*3700 (these dimensions are of a 45,000 liter tank trailer. The dimensions of a tank trailer depends on the capacity and design of it.)

King Pin: 50#(2inch) or 90#(3.5inch) bolt-in type

Tank Body

Tank Shape: Round or square

Tank Material: Aluminum, Tank shell thickness 5 mm, front and rear ends thickness 6mm. Thickness depends on capacity.

Compartments: 1 to 7 compartments, based on customer needs

Baffles: 5 mm thick baffles designed to permit the easy flow of stainless steel inside the tank

Manholes: Each compartment is equipped with 500mm carbon steel or aluminium alloy manhole cover fitted with bolts and nuts, internal safety valve built into the main hole.

Discharge: The tank is top loading through manholes and discharged by gravity through manually operated ball valves 3" or 4", located into a lockable discharged box (at one side of tank). Each compartment is equipped with a lower valves 3" or 4" .

Discharge Pipes: 4" rubber hose, 2 units, 6 metre/each

Walkway: The tank is equipped with upper walkway manufactured from stretched steel sheet and equipped with steel walkwall

Ladder: The tank is equipped with a front or rear ladder to facilitate the arrival to manholes.

Chassis

Landing Legs: 28 ton landing gears with two mechanical speeds. Dynamic: 28 tons; Static 80 tons

Main Beams: Heavy duty and extra durability designed I beam. Made of high tensile steel Q345B, welded by automatic Submerged-Arc processes. Top flange 14 mm thick, bottom 16 mm; web height 500 mm, 8 mm thick

Axles: MAX brand 13 ton axles, 3 – 4 units

Suspensions: Standard mechanical suspensions or air suspensions

Springs: 10 lines of heavy duty leaf springs

Brake System: Dual air brake system

Rims: 9.0-22.5

Tires: 12.00R22.5 tires, 12 units

Electrical: 24 V Lighting system, 7 pole distribution cable and required hardware for traffic regulations

Toolbox: One standard

Spare wheels carriers: Two pieces

Painting: Sandblasting, one coat of primer, two coats of finish painting, and color as per customer's request.

Asphalt Bitumen Tanker Trailer

Asphalt bitumen tanker trailer is mainly used to transport hot asphalt in large quantities for road paving, repair and expansion projects.



Specifications:

Tank Body

Capacity: 38000-42000 liters, according to your requirements

Tank Shape: Round or square

Tank Material: Carbon steel, stainless steel, with insulation layer

Chassis

Landing Legs: 28 ton landing gears with two mechanical speeds. Dynamic: 28 tons; Static 80 tons

Main Beams: Heavy duty and extra durability designed I beam. Made of high tensile steel Q345B, welded by automatic Submerged-Arc processes. Top flange 14 mm thick, bottom 16 mm; web height 500 mm, 8 mm thick

Axles: MAX brand 13 ton axles, 3 – 4 units

Suspensions: Standard mechanical suspensions or air suspensions

Springs: 10 lines of heavy duty leaf springs

Brake System: Dual air brake system

Rims: 9.0-22.5

Tires: 12.00R22.5 tires, 12 units

Electrical: 24 V Lighting system, 7 pole distribution cable and required hardware for traffic regulations

Toolbox: One standard

Spare wheels carriers: Two pieces

Painting: Sandblasting, one coat of primer, two coats of finish painting, and color as per customer's request.

Sulfuric Acid Tanker Trailer

Sulfuric acid tanker trailer is mainly used to transport sulfuric acid.



Specifications:

Capacity: 19-23 CBM, according to your requirements

Tank Shape: Round

Manhole Cover: Stainless steel manhole cover

Landing Legs: 28 ton landing gears with two mechanical speeds. Dynamic: 28 tons; Static 80 tons

Main Beams: Heavy duty and extra durability designed I beam. Made of high tensile steel Q345B, welded by automatic Submerged-Arc processes. Top flange 14 mm thick, bottom 16 mm; web height 500 mm, 8 mm thick

Axles: MAX brand 13 ton axles, 3 – 4 units

Suspensions: Standard mechanical suspensions or air suspensions

Springs: 10 lines of heavy duty leaf springs

Brake System: Dual air brake system

Rims: 9.0-22.5

Tires: 12.00R22.5 tires, 12 units

Electrical: 24 V Lighting system, 7 pole distribution cable and required hardware for traffic regulations

Toolbox: One standard

Spare wheels carriers: Two pieces

Painting: Sandblasting, one coat of primer, two coats of finish painting, and color as per customer's request.

Dry Bulk Semi Trailer

Dry bulk semi trailers are widely used to transport lime, cement, powder.

Customization Options of Dry Bulk Semi Trailer

- Capacity: Ranges from 36 tons to 50 cubic meters
- Shape: single V shaped silo or multiple V shaped silos

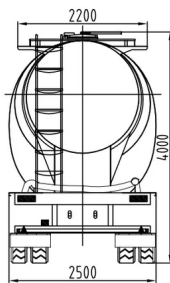
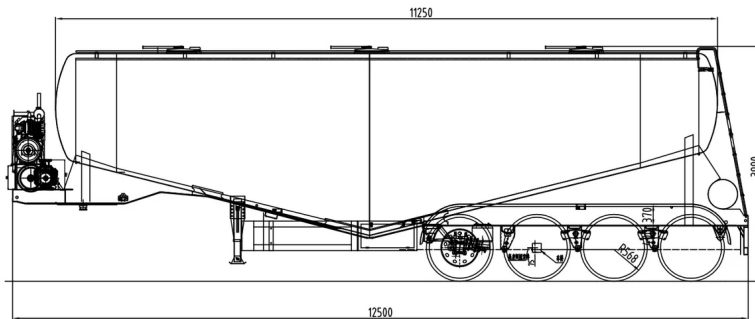

				合同号					
				材质					
审定		设计		名称	中置发动机物料运输车挂车				
审核		制图							
校对		检验	均为内脚尺寸		日期	比例	阶段	数量	*

Please note: this drawing is for a single V-shaped silo dry bulk trailer, the design of your dry bulk semi trailer is as per your requirements.

Specifications:

Silo Shell

Shape: One v-shaped silo or multiple V shaped silos

Shell: 5 mm steel

Dished Ends: 6 mm steel

Diesel Engine: WEICHAH 4102

Compressor: BOHAI 12 m³

Manhole: 500mm Carbon Steel manhole cover

Discharge: Diameter is 3 or 4 inch

Discharging Pipe: 3 or 4 inch rubber hose, 1pcs, 6m/each

Ladder: Ladder to facilitate the arrival to manholes.

Walkway: Walkway manufactured from stretched steel sheet and equipped with steel walk wall.

Chassis

Landing Legs: 28 ton landing gears with two mechanical speeds. Dynamic: 28 tons; Static 80 tons

Main Beams: Heavy duty and extra durability designed I beam. Made of high tensile steel Q345B, welded by automatic Submerged-Arc processes. Top flange 14 mm thick, bottom 16 mm; web height 500 mm, 8 mm thick

Axles: MAX brand 13 ton axles, 3 – 4 units

Suspensions: Standard mechanical suspensions or air suspensions

Springs: 10 lines of heavy duty leaf springs

Brake System: Dual air brake system

Rims: 9.0-22.5

Tires: 12.00R22.5 tires, 12 units

Electrical: 24 V Lighting system, 7 pole distribution cable and required hardware for traffic regulations

Toolbox: One standard

Spare wheels carriers: Two pieces

Painting: Sandblasting, one coat of primer, two coats of finish painting, and color as per customer's request.

Low Bed Semi Trailer

Low bed semi trailers are mainly used to transport construction machinery, industrial equipment, agricultural machinery and other oversized and overweight goods.

Customization Options of Our Low Bed Semi Trailer

- The number of axle ranges from 2 to ten or more
- 13 ton / 14 ton / 15 ton / 16 ton / 20 ton axle option available
- The loading capacity ranges from 50 tons to 200 tons or more
- You can choose mechanical ramp or hydraulic ramp
- Removable gooseneck option available



MX13MLB01

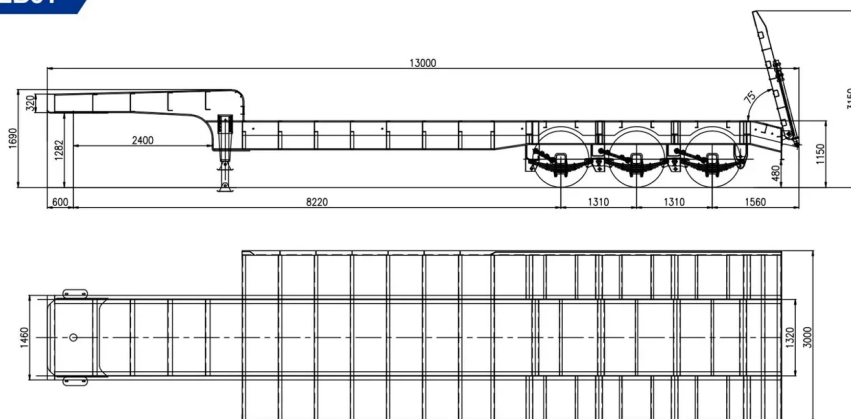

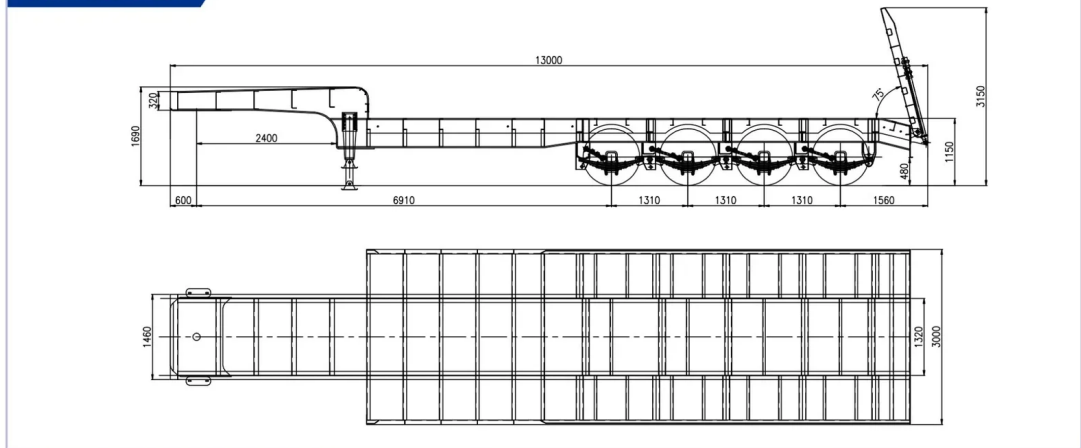
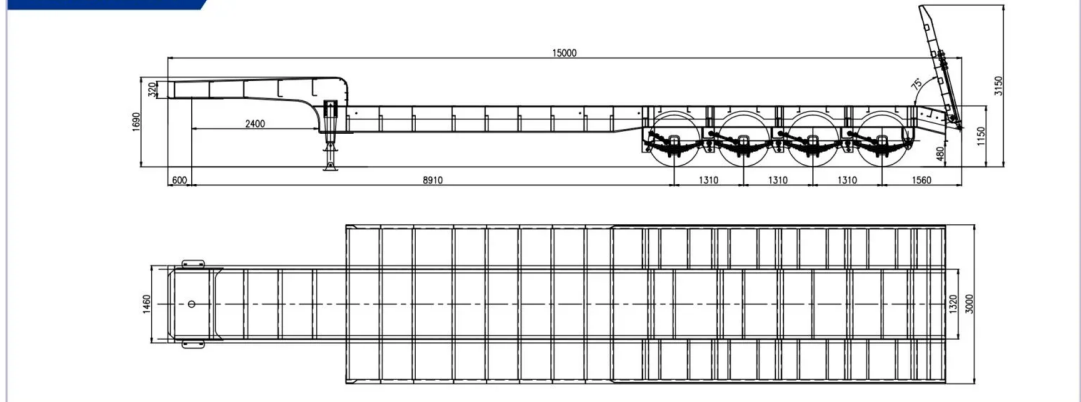
MX13MLB02

MX15MLB01

Specifications:

Dimensions(mm): 13000(Length) × 2500(Width) × 2950(Height)

Payload: 50 tons, depends on the number of axles and the loading capacity of the axles

Main Beams: Heavy duty and extra durability designed I beam. Made of high tensile steel Q345B, welded by automatic Submerged-Arc processes. Top flange 20 mm thick, bottom 20 mm; web height 520 mm, 12 mm thick

Side Beam: 250mm high I beam

Cross Beam: Heavy duty Special U steel

Platform: 5mm checkered steel plate

Kingpin: 50#(2inch) or 90#(3.5inch) bolt-in type

Landing Gear: 28 ton landing gears with two mechanical speeds. Dynamic: 28 tons; Static 80 tons

Axles: 2 to 10 axles or more, 13 ton / 14 ton / 15 ton / 16 ton / 20 ton axles, the regular configuration is three 13 ton axles and the payload will reach 50 tons

Suspensions: mechanical suspensions or air suspensions

Springs: 10 lines of heavy duty leaf springs

Brake System: Dual air brake system

Rims: 6.5, 12 units

Tires: 8.25R20, 12 units

Electrical: 24 V Lighting system, 7 pole distribution cable and required hardware for traffic regulations

Accessories: spare tire carrier + tool box

Painting: Sandblasting, one coat of primer, two coats of finish painting, and color as per customer's request.



Extendable Semi Trailer

Extendable semi trailers are a wide category and they are used to transport a variety of goods according to customer needs.

Extendable semi trailers are highly customized products. Some extendable semi trailers are low bed semi trailers, some of them are flatbed semi trailers and others are designed and produced based on customers' requirements.



Features:

- The extendable semi trailer is made of high tensile steel
- Front extension or rear extension, or both
- Axles: up to 10 axels or more
- Extended length: up to 60 meters or more
- Loading capacity: up to 100 tons or more
- Customer can choose steering axles
- Customer can choose mechanical spring suspension, air suspension, or hydraulic suspension
- Wireless remote control and manual valve operation installed



Removable Gooseneck Semi Trailer

Removable gooseneck semi trailers are widely used to transport tall, heavy, and oversized equipment, such as excavators, bulldozers, cranes, and industrial machinery.

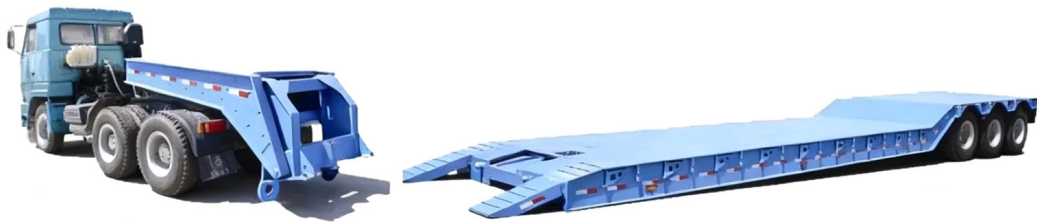

Specifications:

Specifications

Payload: from 60 ton load capacity to 150 ton

Dimensions: as per your requirement

Platform: 3 to 5 mm steel plate

Working Platform Height: 700mm or as per your requirement

Working Platform Length: Customizable

Engine: JAC 12KW

King Pin: 50#(2inch) or 90#(3.5inch) bolt-in type

Trailer body: made of high tensile steel

Landing Gear: 28 ton landing gears with two mechanical speeds. Dynamic: 28

tons; Static 80 tons

Ramp: Optional

Axles: the number of axles and the capacity of axles are as per your requirement

Suspensions: Standard mechanical suspensions

Springs: 10 lines of heavy duty leaf springs

Brake System: Dual air brake system

Electrical: 24 V Lighting system, 7 pole distribution cable and required hardware for traffic regulations

Accessories: spare tire carrier + tool box

Painting: Sandblasting, one coat of primer, two coats of finish painting, and color as per customer's request.

Hydraulic Modular Trailer

Hydraulic modular trailers are used to transport oversized and overweight load, such as bridge sections, buildings, oil rig modules and industrial machinery.



Specifications:

Tare Weight: 3.3 Tons per axle line

Capacity : 34 Tons per axle line at 0.5km/h

Material: S550 high tensile steel, 550Mpa

Wheelbase (mm): 1,550

Platform height (mm): min 770 mm 1080(+290)(-310) mm

Tires: 215/75 R17.5 8 tires per axle line

Approach / Departure angle: 20° / 26°

Support mode of platform: 3 points and 4 points

Max.steering angle of first wheel: + / – 55° in all ride heights

Speed and Axle Load

Speed	Per Axle Load (tons)
0.5	34
5	30.7
10	28.2
20	25.8
30	21.6
40	20
50	18.4

Windmill Blade Adapter

There are two ways to transport wind turbine blades.

On normal road, we use extendable wind blade semi trailers,

In mountain regions we have to use windmill blade adapters.

Max Industries is a leading manufacturer of both extendable wind blade semi trailers and windmill adapters. Not only is Max a well known brand for such trailers in China, but also our products have been exported to many countries including Vietnam, Middle Asia and Vietnam.



Specifications

Function: to transport 56.5 – 76 meter wind turbine blade

Dimensions: 19500mm * 3400mm * 4650mm

Axles: Four lines, eight axles

Tires: 32 unites

Hydraulic Station: 40KW four-cylinder diseal engine

Max Rotation Agle: 360°

Tail: horizontally telescopic pusher with two cylinders

Curtain Trailer

Curtain semi trailers are a category of customized semi trailers.

You tell us your usage, dimensions, payload and other information, and we can design it for you.



Full Drawbar Trailer

We have a lot of experience in designing and manufacturing full drawbar semi trailers.



Car Carrier Semi Trailer

Car carrier semi trailer is a highly customized semi trailer. Max is a professional carrier semi trailer manufacturer in China and our car carrier semi trailers are very popular in domestic market as well as overseas markets.



You can tell us how many cars or SUVs you intend to haul, then we will give you the best solution. After you confirm the drawing and technical details, we can start to produce the car carrier trailers for you.

