

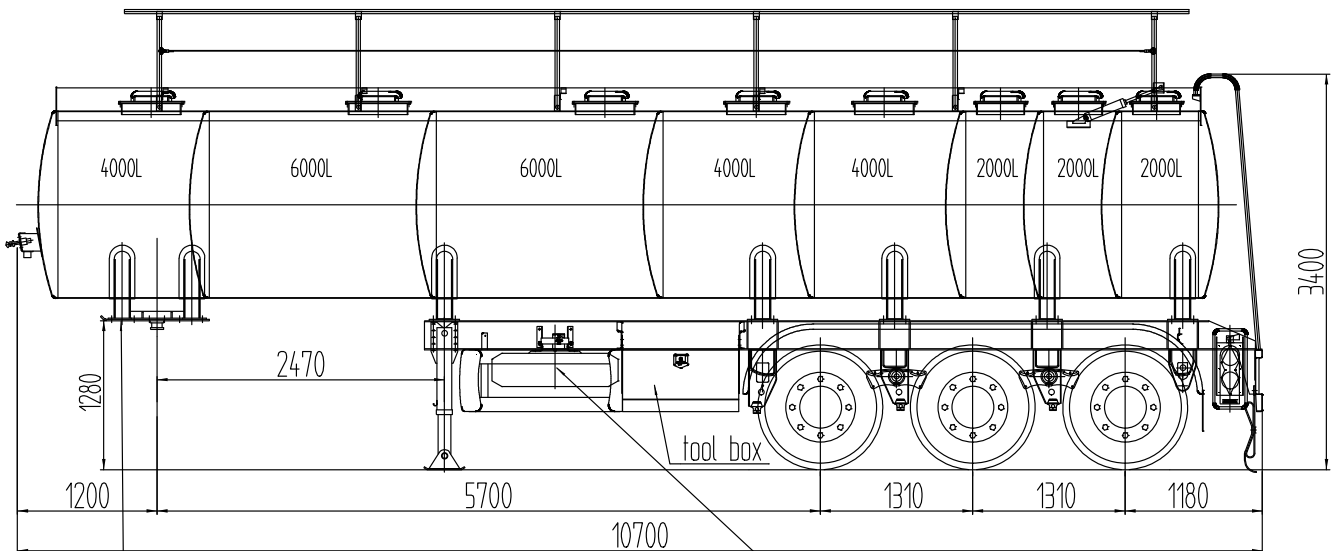

30000 Liter Fuel Tanker Trailer



King Pin Plate Height is 1280mm. It match with the tractor of which the turntable's height is approx 1360mm in idling state.

One wheel holders with carries.

Note: The photo and drawing are for reference only. The final design of the semi trailer is upon your specific requirements.



30000 Liter Fuel Tanker Trailer

Model	MAX/ST/FT/30/001
General	
Dimensions	11250 mm(Length) x 2500 mm(Length) x 3600mm(Height)
Tare Weight	8,500 kg
Payload	30,000 kg
GVWR	38,500 kg
Tank Body	
Tank Shape	Round or square
Tank Capacity	30,000 liters + 6 % expansion approx.
Tank Material	Q235B carbon steel, Tank shell thickness 5 mm , front and rear ends thickness 6mm
Compartments	1 to 7 compartments, based on customer needs
Baffles	5 mm thick baffles designed to permit the easy flow of fuel inside the tank
Manholes	Each compartment is equipped with 500mm carbon steel or aluminium alloy manhole cover fitted with bolts and nuts, internal safety valve built into the main hole.
Discharge	The tank is top loading through manholes and discharged by gravity through manually operated ball valves 3" or 4", located into a lockable discharged box (at one side of tank). Each compartment is equipped with a lower valves 3" or 4" .
Discharge Pipes	4" rubber hose, 2 units, 6 metre/each
Walkway	The tank is equipped with upper walkway manufactured from stretched steel sheet and equipped with steel walkwall
Ladder	The tank is equipped with a front or rear ladder to facilitate the arrival to manholes.
Chassis	
Kingpin	MAX 2.0/3.5 inch
Landing Gears	MAX two speed landing gear, driver side crank
Main Beams	Q345B steel fabricated I beams. Flange width 146 mm, top flange 14 mm thick, bottom flange 16 mm thick. Web height 500 mm, web thickness 8 mm, web stiffeners to prevent beam distortion.
Axles	3 Axles*, MAX brand, each axle capable of carrying minimum 13 tons at 120 km/h speed.
Suspensions	MAX brand standard mechanical suspensions
Brake System	Dual air brake system, WABCO relay emergency valve
Brake Chambers	One axle with T30/30 emergency brake chamber, the other two axles with T30 service brake chambers
Rims	9.00-22.5, 12 units plus one spare
Tires	12.00R22.5, 12 units plus one spare
Electrical	24-Volt sealed wiring harness, 7-pin connector at front
Lights	Standard brake, turn, reverse lamps, one fog lamp
Toolbox	One toolbox with a set of standard trailer tools
Painting	Exterior surface treatment by sandblasting, one coat of primer, two coats of finish painting, color chosen by customer